

Threaded End Connection

Series LS Threaded End Stainless Steel



- Lever Operated Ball Valve
- To 3000 PSI WP
- 1/4" Through 1"
- Threaded Body Construction
 - Meets API 641 Emissions Standard
 - Multi-Seal Seats
 - NACE Standard
 - Exclusive Patented Design Inhibits Loosening of End Adapter
- All Metal Components Made of Stainless Steel
- Maintenance Free
- Fire Safe Design

Material Description

ITEM	PART NAME	MATERIAL (STANDARD)
1	Weather Guard	Polyethylene
2	Stem Nut	Stainless Steel
3	Spacer	Stainless Steel
4	Lock Plate	Stainless Steel
5	Handle*	Stainless Steel
6	Stem Washer	Acetal
7	Stop Pin	Stainless Steel
8	Stem O-Ring	Fluorocarbon
9	Stem Seal	TFE
10	Stem	316 Stainless Steel
11	Body	316 Stainless Steel
12	Ball Seat	Nylon (TFE Optional**)
13	Ball	316 Stainless Steel
14	Body O-Ring	Fluorocarbon
15	Adapter	316 Stainless Steel

* Handle and locking device standard on all Series LS Ball Valves.
 ** Seat selection may result in de-rating of pressure. See Seat Pressure Ratings chart on page B-37 for more information.

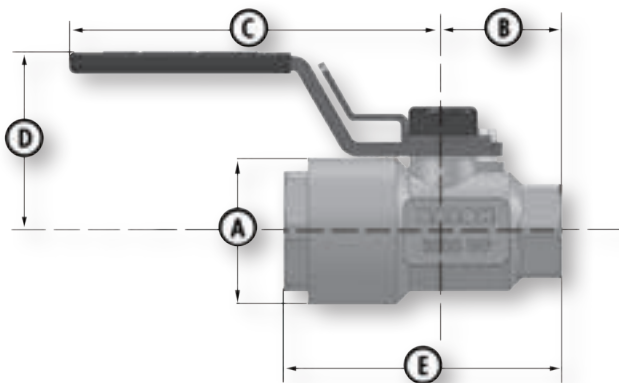
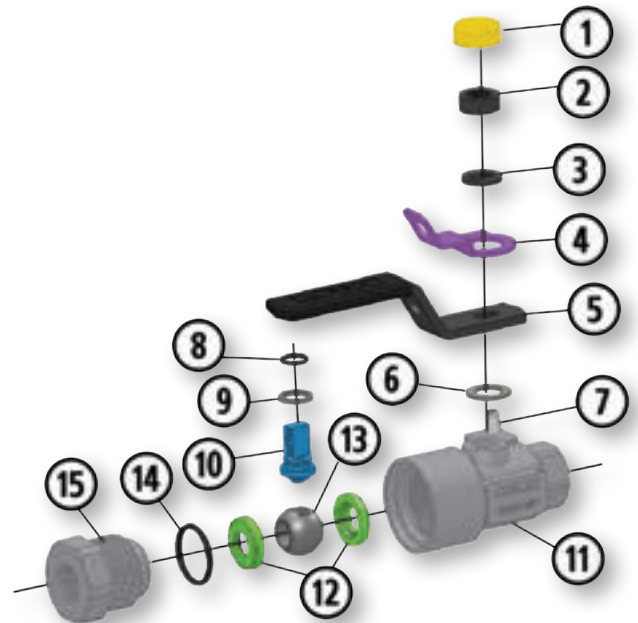

Dimensional Data

SIZE	CATALOG	PORT	WP	A	B	C	D	E	LBS.	Cv
.25x.37x.25	LS-02592	.37	3000	1.37	1.12	3.50	1.62	2.62	.91	-
.50x.37x.50	LS-05561	.37	2000	1.37	1.12	3.50	1.62	2.50	.75	6
.50x.37x.50	LS-05591	.37	3000	1.37	1.43	3.50	1.62	3	1	6
.50x.50x.50	LS-05592	.50	3000	1.58	1.38	3.50	1.96	3.00	2.5	-
.75x.75x.75	LS-07592	.75	3000	2.12	1.75	4.87	2.25	3.75	2.5	-
1x.75x1	LS-10561	.75	2000	2.12	1.87	4.87	2.25	3.75	2	30
1x.75x1	LS-10591	.75	3000	2.12	2	4.87	2.25	4.12	2.5	30